

TOSHIBA

8 Bit Microcontroller
870C Series

TMP86FS49FG

TOSHIBA CORPORATION

The information contained herein is subject to change without notice.

The information contained herein is presented only as a guide for the applications of our products. No responsibility is assumed by TOSHIBA for any infringements of patents or other rights of the third parties which may result from its use. No license is granted by implication or otherwise under any patent or patent rights of TOSHIBA or others.

TOSHIBA is continually working to improve the quality and reliability of its products. Nevertheless, semiconductor devices in general can malfunction or fail due to their inherent electrical sensitivity and vulnerability to physical stress.

It is the responsibility of the buyer, when utilizing TOSHIBA products, to comply with the standards of safety in making a safe design for the entire system, and to avoid situations in which a malfunction or failure of such TOSHIBA products could cause loss of human life, bodily injury or damage to property.

In developing your designs, please ensure that TOSHIBA products are used within specified operating ranges as set forth in the most recent TOSHIBA products specifications.

Also, please keep in mind the precautions and conditions set forth in the "Handling Guide for Semiconductor Devices," or "TOSHIBA Semiconductor Reliability Handbook" etc..

The Toshiba products listed in this document are intended for usage in general electronics applications (computer, personal equipment, office equipment, measuring equipment, industrial robotics, domestic appliances, etc.).

These Toshiba products are neither intended nor warranted for usage in equipment that requires extraordinarily high quality and/or reliability or a malfunction or failure of which may cause loss of human life or bodily injury ("Unintended Usage"). Unintended Usage include atomic energy control instruments, airplane or spaceship instruments, transportation instruments, traffic signal instruments, combustion control instruments, medical instruments, all types of safety devices, etc.. Unintended Usage of Toshiba products listed in this document shall be made at the customer's own risk.

The products described in this document may include products subject to the foreign exchange and foreign trade laws.

TOSHIBA products should not be embedded to the downstream products which are prohibited to be produced and sold, under any law and regulations.

For a discussion of how the reliability of microcontrollers can be predicted, please refer to Section 1.3 of the chapter entitled Quality and Reliability Assurance/Handling Precautions.

© 2004 TOSHIBA CORPORATION
All Rights Reserved

CMOS 8-Bit Microcontroller

TMP86FS49FG

Product No.	FLASH	RAM	PACKAGE	Mask MCU
TMP86FS49FG	60K bytes	2K bytes	P-QFP64-1414-0.80A	TMP86CH49/CM49

1.1 Features

1. 8-bit single chip microcomputer TLCS-870/C series
 - Instruction execution time :
 - 0.25 μ s (at 16 MHz)
 - 122 μ s (at 32.768 kHz)
 - 132 types & 731 basic instructions
2. 24interrupt sources (External : 5 Internal : 19)
3. Input / Output ports (56pins)
4. Time Base Timer
5. Watchdog Timer
6. 16-bit timer counter: 1 ch
 - Timer, External trigger, Window, Pulse width measurement, Event counter, PPG(Programmable Pulse Generator) output modes
7. 16-bit timer counter : 1ch
 - Timer, Event counter, Window modes
8. 8-bit timer counter : 4ch
 - Timer, Event counter, PWM(Pulse width modulation) output, PDO(Programmable Divider Output) output and PPG(Programmable Pulse Generator) modes
9. 8-bit UART: 2ch
10. High-Speed SIO: 2ch
11. Serial Bus Interface(I²C Bus): 1ch

This product uses the Super Flash® technology under the licence of Silicon Storage Technology,Inc. Super Flash® is registered trademark of Silicon Storage Technology,Inc.



Purchase of TOSHIBA I²C components conveys a license under the Philips I²C Patent Rights to use these components in an I²C system, provided that the system conforms to the I²C Standard Specification as defined by Philips.

030619EBP1

- The information contained herein is subject to change without notice.
- The information contained herein is presented only as a guide for the applications of our products. No responsibility is assumed by TOSHIBA for any infringements of patents or other rights of the third parties which may result from its use. No license is granted by implication or otherwise under any patent or patent rights of TOSHIBA or others.
- TOSHIBA is continually working to improve the quality and reliability of its products. Nevertheless, semiconductor devices in general can malfunction or fail due to their inherent electrical sensitivity and vulnerability to physical stress. It is the responsibility of the buyer, when utilizing TOSHIBA products, to comply with the standards of safety in making a safe design for the entire system, and to avoid situations in which a malfunction or failure of such TOSHIBA products could cause loss of human life, bodily injury or damage to property. In developing your designs, please ensure that TOSHIBA products are used within specified operating ranges as set forth in the most recent TOSHIBA products specifications. Also, please keep in mind the precautions and conditions set forth in the " Handling Guide for Semiconductor Devices, " or " TOSHIBA Semiconductor Reliability Handbook " etc..
- The TOSHIBA products listed in this document are intended for usage in general electronics applications (computer, personal equipment, office equipment, measuring equipment, industrial robotics, domestic appliances, etc.). These TOSHIBA products are neither intended nor warranted for usage in equipment that requires extraordinarily high quality and/or reliability or a malfunction or failure of which may cause loss of human life or bodily injury (" Unintended Usage "). Unintended Usage include atomic energy control instruments, airplane or spaceship instruments, transportation instruments, traffic signal instruments, combustion control instruments, medical instruments, all types of safety devices, etc.. Unintended Usage of TOSHIBA products listed in this document shall be made at the customer ' s own risk.
- The products described in this document are subject to the foreign exchange and foreign trade laws.
- TOSHIBA products should not be embedded to the downstream products which are prohibited to be produced and sold, under any law and regulations.
- For a discussion of how the reliability of microcontrollers can be predicted, please refer to Section 1.3 of the chapter entitled Quality and Reliability Assurance/Handling Precautions.

12. 10-bit successive approximation type AD converter

Analog inputs: 16ch

13. Key On Wake Up : 4ch

14. Clock operation

Single clock mode

Dual clock mode

15. Low power consumption operation

STOP mode: Oscillation stops. (Battery/Capacitor back-up.)

SLOW1 mode: Low power consumption operation using low-frequency clock.(High-frequency clock stop.)

SLOW2 mode: Low power consumption operation using low-frequency clock.(High-frequency clock oscillate.)

IDLE0 mode: CPU stops, and only the Time-Based-Timer(TBT) on peripherals operate using high frequency clock. Release by falling edge of the source clock which is set by TBTCR<TBTCK>.

IDLE1 mode: CPU stops and peripherals operate using high frequency clock. Release by interrupts(CPU restarts).

IDLE2 mode: CPU stops and peripherals operate using high and low frequency clock. Release by interrupts. (CPU restarts).

SLEEP0 mode: CPU stops, and only the Time-Based-Timer(TBT) on peripherals operate using low frequency clock.Release by falling edge of the source clock which is set by TBTCR<TBTCK>.

SLEEP1 mode: CPU stops, and peripherals operate using low frequency clock. Release by interrupt.(CPU restarts).

SLEEP2 mode: CPU stops and peripherals operate using high and low frequency clock. Release by interrupt.

16. Wide operation voltage:

4.5 V~5.5 V at 16.0MHz /32.768 kHz

3.0 V~3.6 V at 8 MHz /32.768 kHz

1.2 Pin Assignment

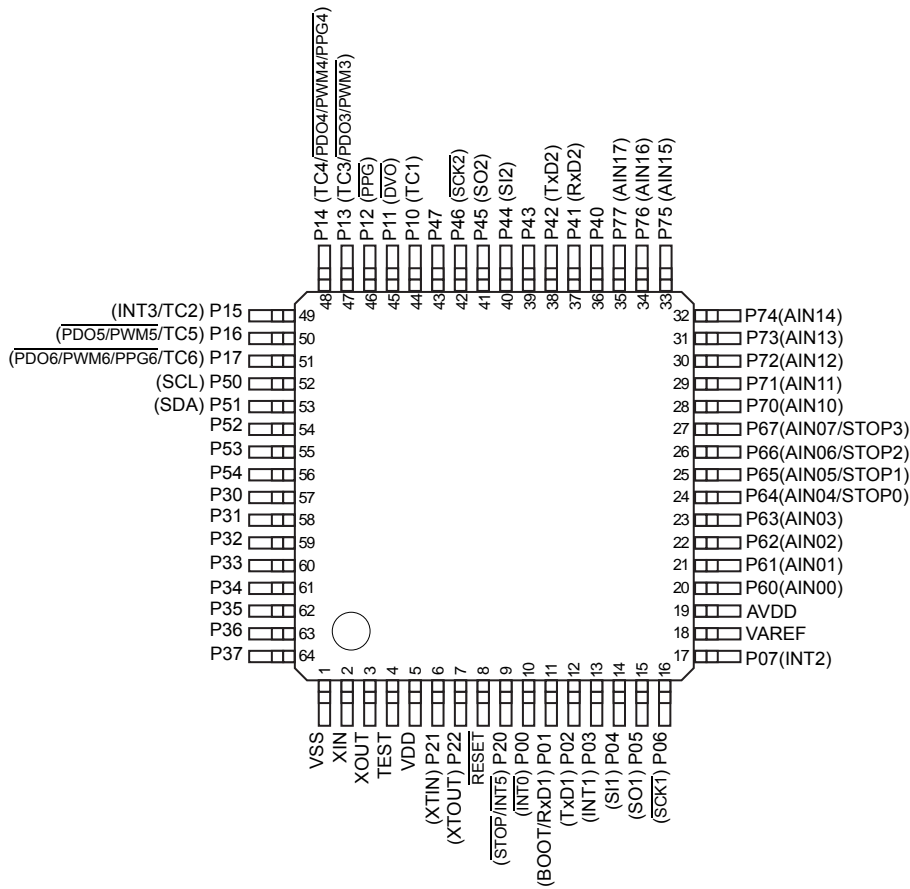

Figure 1-1 Pin Assignment

1.3 Block Diagram

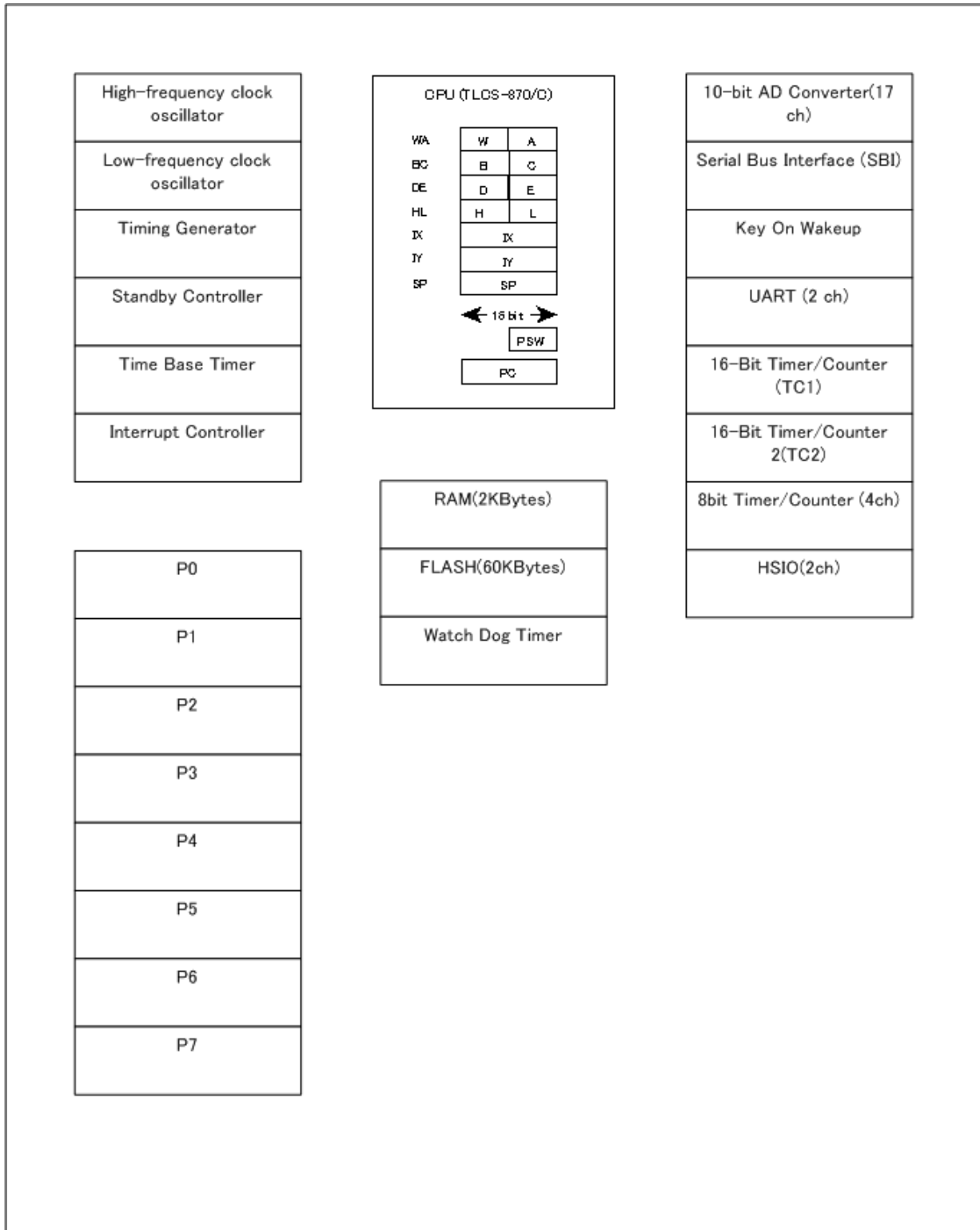

Figure 1-2 Block Diagram

1.4 Pin Names and Functions

Table 1-1 Pin Names and Functions (1/3)

Pin Name	Pin Number	Input/Output	Functions
P07 INT2	17	IO I	PORT07 External interrupt 2 input
P06 SCK1	16	IO IO	PORT06 Serial clock input/output 1
P05 SO1	15	IO O	PORT05 Serial data output 1
P04 SI1	14	IO I	PORT04 Serial data input 1
P03 INT1	13	IO I	PORT03 External interrupt 1 input
P02 TxD1	12	IO O	PORT02 UART data output 1
P01 RxD1 BOOT	11	IO I I	PORT01 UART data input 1 Serial PROM mode control input
P00 INT0	10	IO I	PORT00 External interrupt 0 input
P17 TC6 PDO6/PWM6/PPG6	51	IO I O	PORT17 Timer counter 6 input PDO6/PWM6/PPG6 output
P16 TC5 PDO5/PWM5	50	IO I O	PORT16 Timer counter 5 input PDO5/PWM5 output
P15 TC2 INT3	49	IO I I	PORT15 Timer counter 2 input External interrupt 3 input
P14 TC4 PDO4/PWM4/PPG4	48	IO I O	PORT14 Timer counter 4 input PDO4/PWM4/PPG4 output
P13 TC3 PDO3/PWM3	47	IO I O	PORT13 Timer counter 3 input PDO3/PWM3 output
P12 PPG	46	IO I	PORT12 PPG Output
P11 DVO	45	IO O	PORT11 Divider output
P10 TC1	44	IO I	PORT10 Timer counter 1 input
P22 XTOUT	7	IO O	PORT22 Resonator connecting pins(32.768kHz) for inputting external clock
P21 XTIN	6	IO I	PORT21 Resonator connecting pins(32.768kHz) for inputting external clock
P20 INT5 STOP	9	IO I I	PORT20 External interrupt 5 input STOP mode release signal input

Table 1-1 Pin Names and Functions (2/3)

Pin Name	Pin Number	Input/Output	Functions
P37	64	IO	PORT37
P36	63	IO	PORT36
P35	62	IO	PORT35
P34	61	IO	PORT34
P33	60	IO	PORT33
P32	59	IO	PORT32
P31	58	IO	PORT31
P30	57	IO	PORT30
P47	43	IO	PORT47
P46 SCK2	42	IO IO	PORT46 Serial clock input/output 2
P45 SO2	41	IO O	PORT45 Serial data output 2
P44 SI2	40	IO I	PORT44 Serial data input 2
P43	39	IO	PORT43
P42 TxD2	38	IO O	PORT42 UART data output 2
P41 RxD2	37	IO I	PORT41 UART data input 2
P40	36	IO	PORT40
P54	56	IO	PORT54
P53	55	IO	PORT53
P52	54	IO	PORT52
P51 SDA	53	IO IO	PORT51 I2C bus serial data input/output
P50 SCL	52	IO IO	PORT50 I2C bus serial clock input/output
P67 AIN07 STOP3	27	IO I I	PORT67 AD converter analog input 7 STOP3 input
P66 AIN06 STOP2	26	IO I I	PORT66 AD converter analog input 6 STOP2 input
P65 AIN05 STOP1	25	IO I I	PORT65 AD converter analog input 5 STOP1 input
P64 AIN04 STOP0	24	IO I I	PORT64 AD converter analog input 4 STOP0 input
P63 AIN03	23	IO I	PORT63 AD converter analog input 3
P62 AIN02	22	IO I	PORT62 AD converter analog input 2

Table 1-1 Pin Names and Functions (3/3)

Pin Name	Pin Number	Input/Output	Functions
P61 AIN01	21	IO I	PORT61 AD converter analog input 1
P60 AIN00	20	IO I	PORT60 AD converter analog input 0
P77 AIN17	35	IO I	PORT77 AD converter analog input 17
P76 AIN16	34	IO I	PORT76 AD converter analog input 16
P75 AIN15	33	IO I	PORT75 AD converter analog input 15
P74 AIN14	32	IO I	PORT74 AD converter analog input 14
P73 AIN13	31	IO I	PORT73 AD converter analog input 13
P72 AIN12	30	IO I	PORT72 AD converter analog input 12
P71 AIN11	29	IO I	PORT71 AD converter analog input 11
P70 AIN10	28	IO I	PORT70 AD converter analog input 10
XIN	2	I	Resonator connecting pins for high-frequency clock
XOUT	3	O	Resonator connecting pins for high-frequency clock
$\overline{\text{RESET}}$	8	I	Reset signal input
TEST	4	I	Test pin for out-going test and the Serial PROM mode control pin. Usually fix to low level. Fix to high level when the Serial PROM mode starts.
VAREF	18	I	Analog reference voltage input (High)
AVDD	19	I	AD circuit power supply
VDD	5	I	+5V
VSS	1	I	0(GND)

2. Operational Description

2.1 CPU Core Functions

The CPU core consists of a CPU, a system clock controller, and an interrupt controller.

This section provides a description of the CPU core, the program memory, the data memory, and the reset circuit.

2.1.1 Memory Address Map

The TMP86FS49FG memory consists of 4 blocks: FLASH, RAM, DBR (Data buffer register) and SFR (Special function register). They are all mapped in 64-Kbyte address space. Figure 2-1 shows the TMP86FS49FG memory address map. The general-purpose registers are not assigned to the RAM address space.

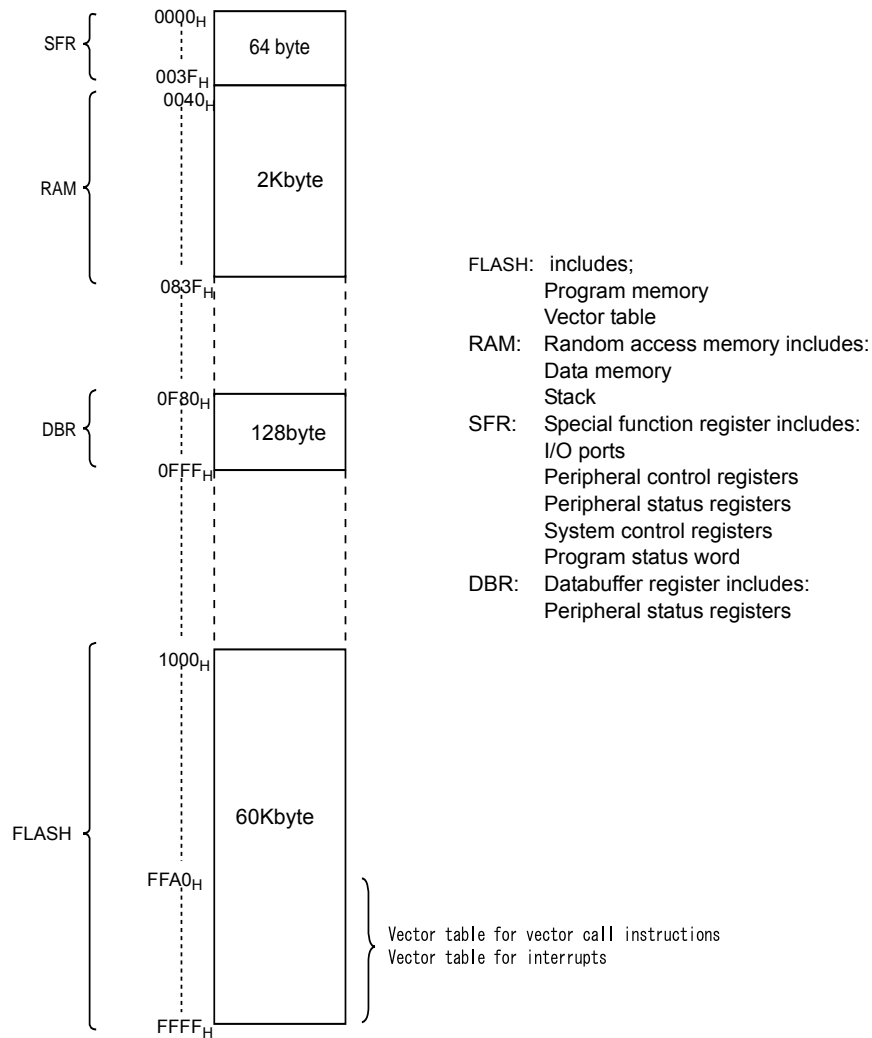

Figure 2-1 Memory Address Map

2.1.2 Program Memory (FLASH)

The TMP86FS49FG has a 60K × 8 bits (Address 1000H to FFFFH) of program memory (FLASH). A program code placed on the internal RAM can be executable when a certain procedure is executed (See "2.3.2 Address trap reset ").

2.1.3 Data Memory (RAM)

Data memory consists of internal data memory (Internal FLASH or RAM). The TMP86FS49FG has 2Kbyte (Address 0040H to 083FH) of internal RAM. The first 192 bytes (0040H to 00FFH) of the internal RAM are located in the direct area; instructions with shorten operations are available against such an area.

The data memory contents become unstable when the power supply is turned on; therefore, the data memory should be initialized by an initialization routine.

Example :Clears RAM to "00H". (TMP86FS49FG)

```

LD      HL, 0040H      ; Start address setup
LD      A, H          ; Initial value (00H) setup
LD      BC, 07FFH     ;
SRAMCLR: LD      (HL), A
INC     HL
DEC     BC
JRS    F, SRAMCLR

```

2.2 System Clock Controller

The system clock controller consists of a clock generator, a timing generator, and a standby controller.

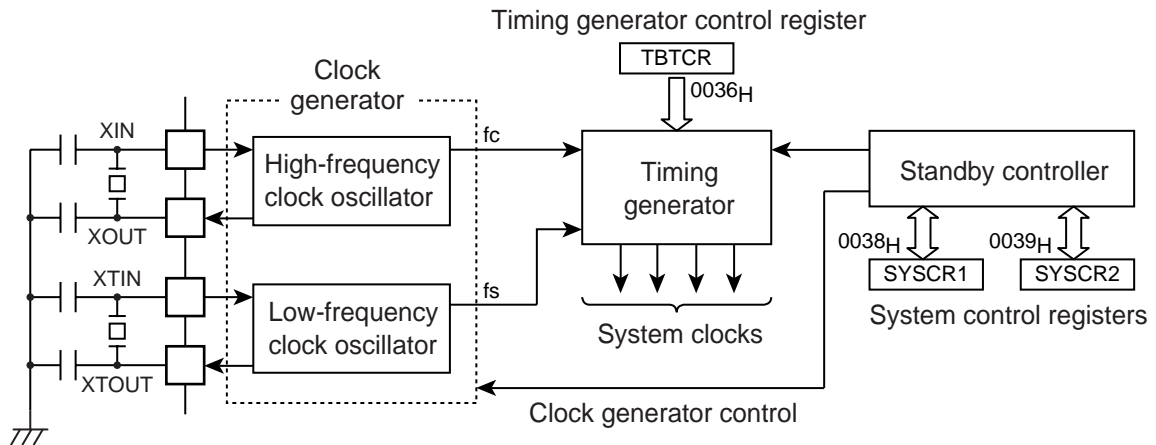

Figure 2-2 System Colck Control

2.2.1 Clock Generator

The clock generator generates the basic clock which provides the system clocks supplied to the CPU core and peripheral hardware. It contains two oscillation circuits: One for the high-frequency clock and one for the low-frequency clock. Power consumption can be reduced by switching of the standby controller to low-power operation based on the low-frequency clock.

The high-frequency (f_c) clocks and low-frequency (f_s) clock can easily be obtained by connecting a resonator between the XIN/XOUT and XTIN/XTOUT pins respectively. Clock input from an external oscillator is also possible. In this case, external clock is applied to XIN/XTIN pin with XOUT/XTOUT pin not connected.

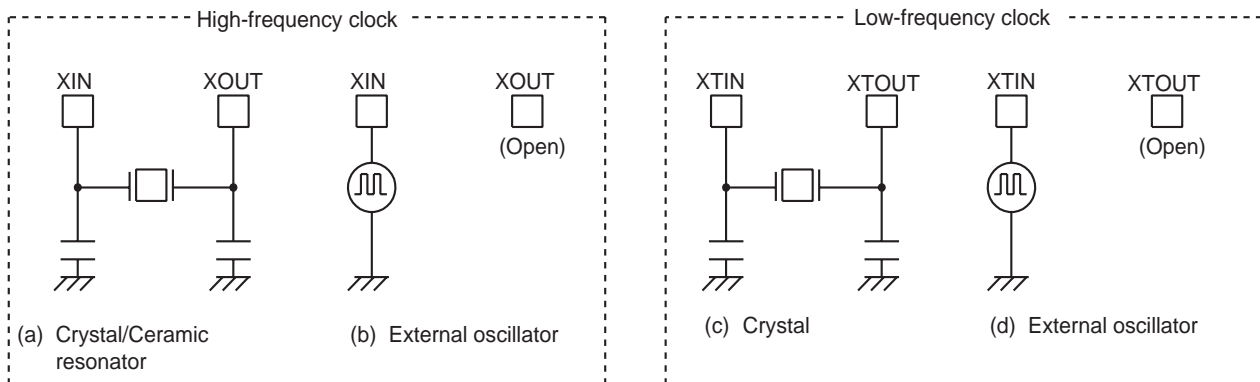

Figure 2-3 Examples of Resonator Connection

Note: The function to monitor the basic clock directly at external is not provided for hardware, however, with disabling all interrupts and watchdog timers, the oscillation frequency can be adjusted by monitoring the pulse which the fixed frequency is outputted to the port by the program. The system to require the adjustment of the oscillation frequency should create the program for the adjustment in advance.

2.2.2 Timing Generator

The timing generator generates the various system clocks supplied to the CPU core and peripheral hardware from the basic clock (f_c or f_s). The timing generator provides the following functions.

1. Generation of main system clock
2. Generation of divider output (\overline{DVO}) pulses
3. Generation of source clocks for time base timer
4. Generation of source clocks for watchdog timer
5. Generation of internal source clocks for timer/counters
6. Generation of warm-up clocks for releasing STOP mode

2.2.2.1 Configuration of timing generator

The timing generator consists of a 2-stage prescaler, a 21-stage divider, a main system clock generator, and machine cycle counters.

An input clock to the 7th stage of the divider depends on the operating mode, DV7CK (Bit4 in TBTCR), that is shown in Figure 1-5. As reset and STOP mode started/canceled, the prescaler and the divider are cleared to "0".

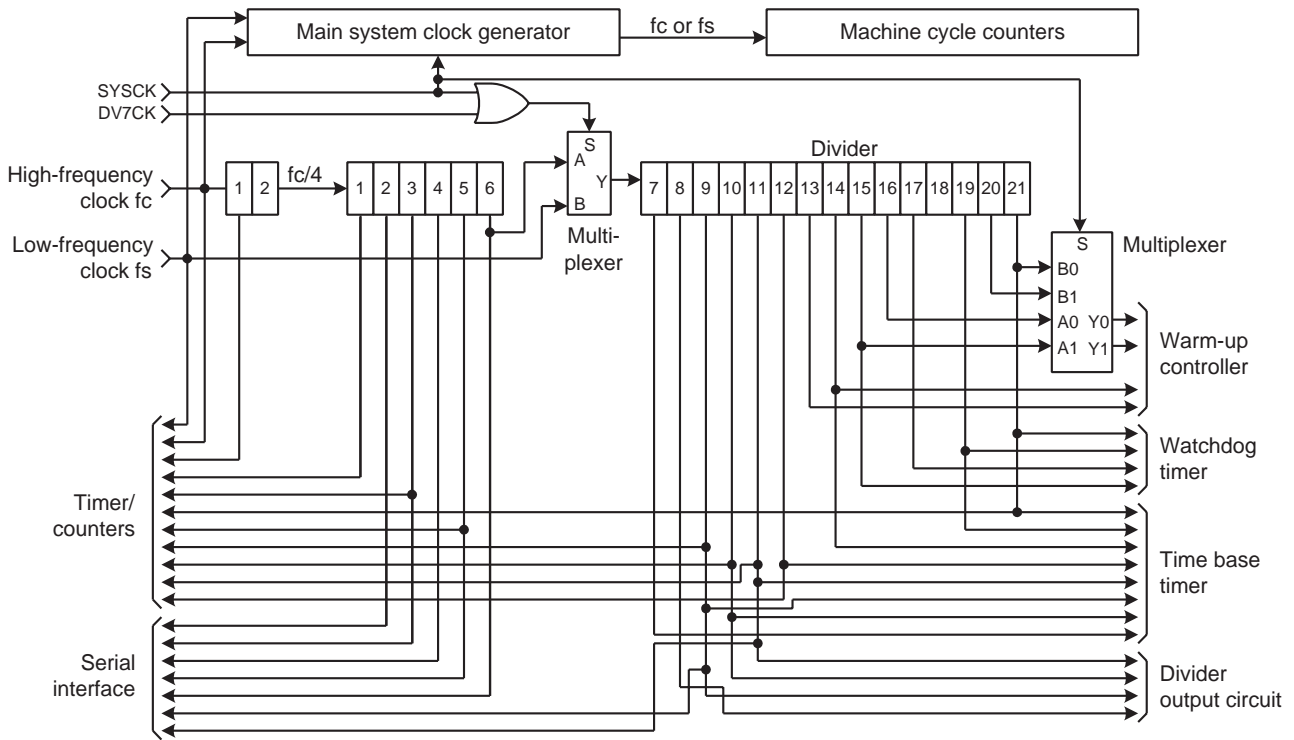

Figure 2-4 Configuration of Timing Generator

Timing Generator Control Register

TBTCR (0036H)	7	6	5	4	3	2	1	0	(Initial value: 0000 0000)
	(DVOEN)	(DVOCK)	DV7CK	(TBTEN)	(TBTCK)				
	DV7CK	Selection of input to the 7th stage of the divider		0: $fc/2^8$ [Hz] 1: fs				R/W	

- Note 1: In single clock mode, do not set DV7CK to "1".
- Note 2: Do not set "1" on DV7CK while the low-frequency clock is not operated stably.
- Note 3: fc: High-frequency clock [Hz], fs: Low-frequency clock [Hz], *: Don't care
- Note 4: In SLOW1/2 and SLEEP1/2 modes, the DV7CK setting is ineffective, and fs is input to the 7th stage of the divider.
- Note 5: When STOP mode is entered from NORMAL1/2 mode, the DV7CK setting is ineffective during the warm-up period after release of STOP mode, and the 6th stage of the divider is input to the 7th stage during this period.

2.2.2.2 Machine cycle

Instruction execution and peripheral hardware operation are synchronized with the main system clock.

The minimum instruction execution unit is called an "machine cycle". There are a total of 10 different types of instructions for the TLCS-870/C Series: Ranging from 1-cycle instructions which require one machine cycle for execution to 10-cycle instructions which require 10 machine cycles for execution. A machine cycle consists of 4 states (S0 to S3), and each state consists of one main system clock.

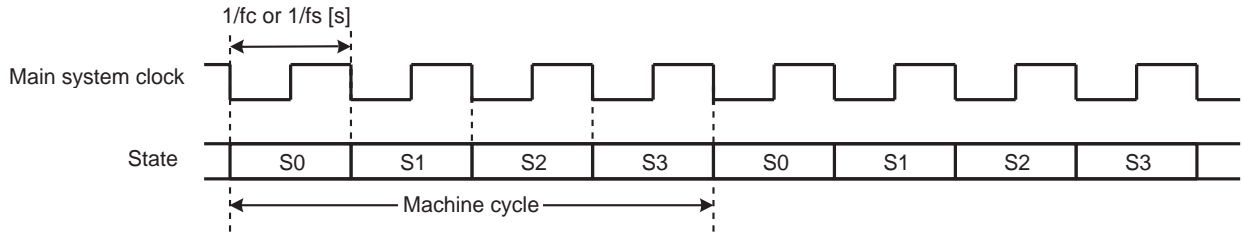

Figure 2-5 Machine Cycle

2.2.3 Operation Mode Control Circuit

The operation mode control circuit starts and stops the oscillation circuits for the high-frequency and low-frequency clocks, and switches the main system clock. There are two operating modes: Single clock and dual clock. These modes are controlled by the system control registers (SYSCR1 and SYSCR2).

Figure 2-6 shows the operating mode transition diagram.

2.2.3.1 Single-clock mode

Only the oscillation circuit for the high-frequency clock is used, and P21 (XTIN) and P22 (XTOUT) pins are used as input/output ports. The main-system clock is obtained from the high-frequency clock. In the single-clock mode, the machine cycle time is $4/f_c$ [s].

(1) NORMAL1 mode

In this mode, both the CPU core and on-chip peripherals operate using the high-frequency clock.

The TMP86FS49FG is placed in this mode after reset.

(2) IDLE1 mode

In this mode, the internal oscillation circuit remains active. The CPU and the watchdog timer are halted; however on-chip peripherals remain active (Operate using the high-frequency clock).

IDLE1 mode is started by SYSCR2<IDLE>, and IDLE1 mode is released to NORMAL1 mode by an interrupt request from the on-chip peripherals or external interrupt inputs. When the IMF (Interrupt master enable flag) is "1" (Interrupt enable), the execution will resume with the acceptance of the interrupt, and the operation will return to normal after the interrupt service is completed. When the IMF is "0" (Interrupt disable), the execution will resume with the instruction which follows the IDLE1 mode start instruction.

(3) IDLE0 mode

In this mode, all the circuit, except oscillator and the timer-base-timer, stops operation.

This mode is enabled by setting "1" on bit TGHALT on the system control register 2 (SYSCR2).

When IDLE0 mode starts, the CPU stops and the timing generator stops feeding the clock to the peripheral circuits other than TBT. Then, upon detecting the falling edge of the source clock selected with TBTCR<TBTCCK>, the timing generator starts feeding the clock to all peripheral circuits.

When returned from IDLE0 mode, the CPU restarts operating, entering NORMAL1 mode back again. IDLE0 mode is entered and returned regardless of how TBTCR<TBTEN> is set. When IMF = “1”, EF6 (TBT interrupt individual enable flag) = “1”, and TBTCR<TBTEN> = “1”, interrupt processing is performed. When IDLE0 mode is entered while TBTCR<TBTEN> = “1”, the INTTBT interrupt latch is set after returning to NORMAL1 mode.

2.2.3.2 Dual-clock mode

Both the high-frequency and low-frequency oscillation circuits are used in this mode. P21 (XTIN) and P22 (XTOUT) pins cannot be used as input/output ports. The main system clock is obtained from the high-frequency clock in NORMAL2 and IDLE2 modes, and is obtained from the low-frequency clock in SLOW and SLEEP modes. The machine cycle time is $4/f_c$ [s] in the NORMAL2 and IDLE2 modes, and $4/f_s$ [s] (122 ms at $f_s = 32.768$ kHz) in the SLOW and SLEEP modes.

The TLCS-870/C is placed in the signal-clock mode during reset. To use the dual-clock mode, the low-frequency oscillator should be turned on at the start of a program.

(1) NORMAL2 mode

In this mode, the CPU core operates with the high-frequency clock. On-chip peripherals operate using the high-frequency clock and/or low-frequency clock.

(2) SLOW2 mode

In this mode, the CPU core operates with the low-frequency clock, while both the high-frequency clock and the low-frequency clock are operated. On-chip peripherals are triggered by the low-frequency clock. As the SYSCK on SYSCR2 becomes “0”, the hardware changes into NORMAL2 mode. As the XEN on SYSCR2 becomes “0”, the hardware changes into SLOW1 mode. Do not clear XTEN to “0” during SLOW2 mode.

(3) SLOW1 mode

This mode can be used to reduce power-consumption by turning off oscillation of the high-frequency clock. The CPU core and on-chip peripherals operate using the low-frequency clock.

Switching back and forth between SLOW1 and SLOW2 modes are performed by XEN bit on the system control register 2 (SYSCR2). In SLOW1 and SLEEP modes, the input clock to the 1st stage of the divider is stopped; output from the 1st to 6th stages is also stopped.

(4) IDLE2 mode

In this mode, the internal oscillation circuit remain active. The CPU and the watchdog timer are halted; however, on-chip peripherals remain active (Operate using the high-frequency clock and/or the low-frequency clock). Starting and releasing of IDLE2 mode are the same as for IDLE1 mode, except that operation returns to NORMAL2 mode.

(5) SLEEP1 mode

In this mode, the internal oscillation circuit of the low-frequency clock remains active. The CPU, the watchdog timer, and the internal oscillation circuit of the high-frequency clock are halted; however, on-chip peripherals remain active (Operate using the low-frequency clock). Starting and releasing of SLEEP mode are the same as for IDLE1 mode, except that operation returns to SLOW mode. In SLOW and SLEEP modes, the input clock to the 1st stage of the divider is stopped; output from the 1st to 6th stages is also stopped.

(6) SLEEP2 mode

The SLEEP2 mode is the idle mode corresponding to the SLOW2 mode. The status under the SLEEP2 mode is same as that under the SLEEP1 mode, except for the oscillation circuit of the high-frequency clock.

(7) SLEEP0 mode

In this mode, all the circuit, except oscillator and the timer-base-timer, stops operation. This mode is enabled by setting "1" on bit TGHALT on the system control register 2 (SYSCR2).

When SLEEP0 mode starts, the CPU stops and the timing generator stops feeding the clock to the peripheral circuits other than TBT. Then, upon detecting the falling edge of the source clock selected with TBTCCR<TBTCK>, the timing generator starts feeding the clock to all peripheral circuits.

When returned from SLEEP0 mode, the CPU restarts operating, entering SLOW1 mode back again. SLEEP0 mode is entered and returned regardless of how TBTCCR<TBTEN> is set. When IMF = "1", EF6 (TBT interrupt individual enable flag) = "1", and TBTCCR<TBTEN> = "1", interrupt processing is performed. When SLEEP0 mode is entered while TBTCCR<TBTEN> = "1", the INTTBT interrupt latch is set after returning to SLOW1 mode.

2.2.3.3 STOP mode

In this mode, the internal oscillation circuit is turned off, causing all system operations to be halted. The internal status immediately prior to the halt is held with a lowest power consumption during STOP mode.

STOP mode is started by the system control register 1 (SYSCR1), and STOP mode is released by a inputting (Either level-sensitive or edge-sensitive can be programmably selected) to the $\overline{\text{STOP}}$ pin. After the warm-up period is completed, the execution resumes with the instruction which follows the STOP mode start instruction.

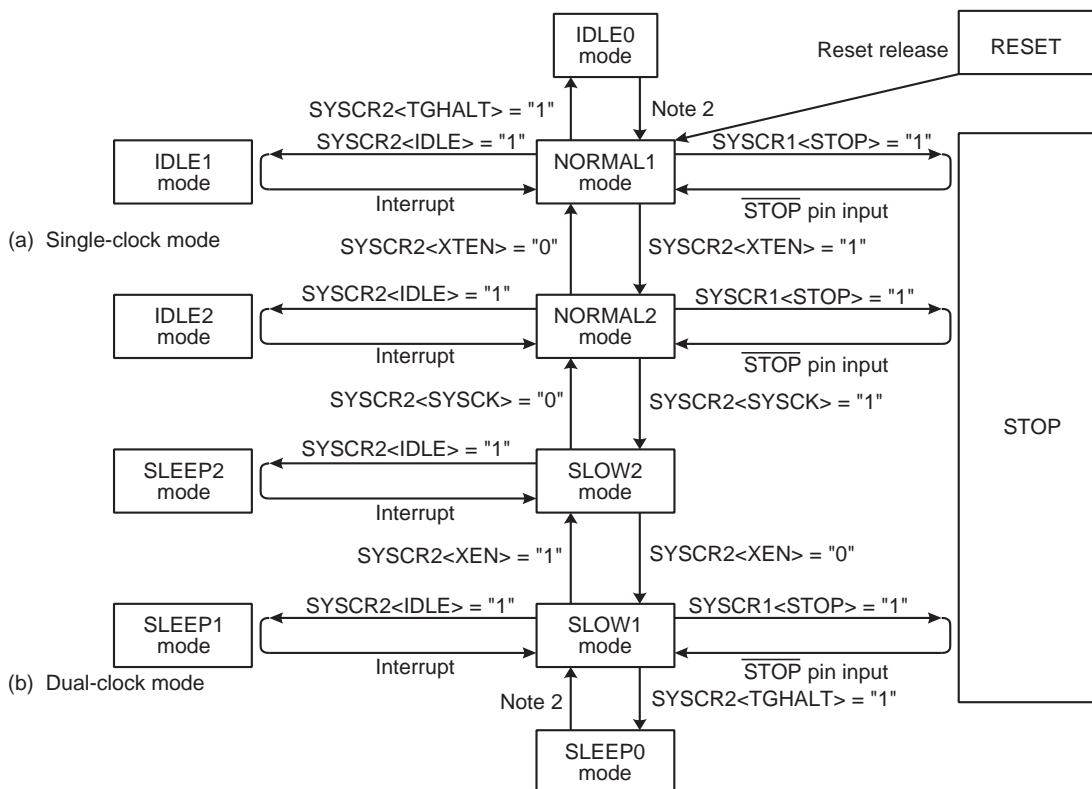

Note 1: NORMAL1 and NORMAL2 modes are generically called NORMAL; SLOW1 and SLOW2 are called SLOW; IDLE0, IDLE1 and IDLE2 are called IDLE; SLEEP0, SLEEP1 and SLEEP2 are called SLEEP.

TENTATIVE

Note 2: The mode is released by falling edge of TBTCR<TBTCCK> setting.

Figure 2-6 Operating Mode Transition Diagram

Operating Mode		Oscillator		CPU Core	TBT	Other Peripherals	Machine Cycle Time		
		High Frequency	Low Frequency						
Single clock	RESET	Oscillation	Stop	Reset	Reset	Reset	4/fc [s]		
	NORMAL1			Operate	Operate	Operate			
	IDLE1			Halt			Operate	Halt	
	IDLE0								
	STOP	Stop	Halt	Halt	-				
Dual clock	NORMAL2	Oscillation	Oscillation	Operate with high frequency	Operate	Operate	4/fc [s]		
	IDLE2			Halt					
	SLOW2			Operate with low frequency					
	SLEEP2			Halt					
	SLOW1	Stop	Oscillation	Operate with low frequency			Operate	Operate	4/fs [s]
	SLEEP1			Halt					
	SLEEP0								
	STOP			Stop					

System Control Register 1

SYSCR1 (0038H)	7	6	5	4	3	2	1	0	(Initial value: 0000 00**)
	STOP	RELM	RETM	OUTEN	WUT				

STOP	STOP mode start	0: CPU core and peripherals remain active 1: CPU core and peripherals are halted (Start STOP mode)		R/W
RELM	Release method for STOP mode	0: Edge-sensitive release 1: Level-sensitive release		
RETM	Operating mode after STOP mode	0: Return to NORMAL1/2 mode 1: Return to SLOW1 mode		
OUTEN	Port output during STOP mode	0: High impedance 1: Output kept		
WUT	Warm-up time at releasing STOP mode		Return to NORMAL mode	
		00	$3 \times 2^{16}/fc$	$3 \times 2^{13}/fs$
		01	$2^{16}/fc$	$2^{13}/fs$
		10	$3 \times 2^{14}/fc$	$3 \times 2^6/fs$
		11	$2^{14}/fc$	$2^6/fs$

Note 1: Always set RETM to "0" when transiting from NORMAL mode to STOP mode. Always set RETM to "1" when transiting from SLOW mode to STOP mode.

Note 2: When STOP mode is released with \overline{RESET} pin input, a return is made to NORMAL1 regardless of the RETM contents.

Note 3: fc: High-frequency clock [Hz], fs: Low-frequency clock [Hz], *: Don't care

Note 4: Bits 1 and 0 in SYSCR1 are read as undefined data when a read instruction is executed.

Note 5: As the hardware becomes STOP mode under OUTEN = "0", input value is fixed to "0"; therefore it may cause interrupt request on account of falling edge.

Note 6: When the key-on wakeup is used, the edge release can not function according to some conditions. It is recommended to set the level release (RELM = "1").

Note 7: Port P20 is used as \overline{STOP} pin. Therefore, when stop mode is started, OUTEN does not affect to P20, and P20 becomes High-Z mode.

Note 8: The warmig-up time should be set correctly for using oscillator.

System Control Register 2

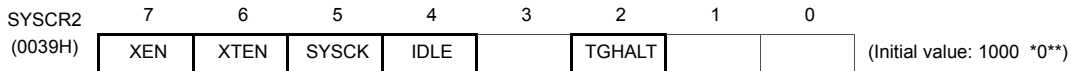

XEN	High-frequency oscillator control	0: Turn off oscillation 1: Turn on oscillation	R/W
XTEN	Low-frequency oscillator control	0: Turn off oscillation 1: Turn on oscillation	
SYSCK	Main system clock select (Write)/main system clock monitor (Read)	0: High-frequency clock 1: Low-frequency clock	
IDLE	CPU and watchdog timer control (IDLE1/2 and SLEEP1/2 modes)	0: CPU and watchdog timer remain active 1: CPU and watchdog timer are stopped (Start IDLE1/2 and SLEEP1/2 modes)	
TGHALT	TG control (IDLE0 and SLEEP0 modes)	0: Feeding clock to all peripherals from TG 1: Stop feeding clock to peripherals except TBT from TG. (Start IDLE0 and SLEEP0 modes)	

- Note 1: A reset is applied if both XEN and XTEN are cleared to "0", XEN is cleared to "0" when SYSCK = "0", or XTEN is cleared to "0" when SYSCK = "1".
- Note 2: *: Don't care, TG: Timing generator
- Note 3: Bits 3, 1 and 0 in SYSCR2 are always read as undefined value.
- Note 4: Do not set IDLE and TGHALT to "1" simultaneously.
- Note 5: Because returning from IDLE0/SLEEP0 to NORMAL1/SLOW1 is executed by the asynchronous internal clock, the period of IDLE0/SLEEP0 mode might be shorter than the period setting by TBTCR<TBTCCK>.
- Note 6: When IDLE1/2 or SLEEP1/2 mode is released, IDLE is automatically cleared to "0".
- Note 7: When IDLE0 or SLEEP0 mode is released, TGHALT is automatically cleared to "0".
- Note 8: Before setting TGHALT to "1", be sure to stop peripherals. If peripherals are not stopped, the interrupt latch of peripherals may be set after IDLE0 or SLEEP0 mode is released.

2.2.4 Operating Mode Control

2.2.4.1 STOP mode

STOP mode is controlled by the system control register 1, the \overline{STOP} pin input .
The \overline{STOP} pin is also used both as a port P20 and an $\overline{INT5}$ (external interrupt input 5) pin.

STOP mode is started by setting STOP (Bit7 in SYSCR1) to "1". During STOP mode, the following status is maintained.

1. Oscillations are turned off, and all internal operations are halted.
2. The data memory, registers, the program status word and port output latches are all held in the status in effect before STOP mode was entered.
3. The prescaler and the divider of the timing generator are cleared to "0".
4. The program counter holds the address 2 ahead of the instruction (e.g., [SET (SYSCR1).7]) which started STOP mode.

STOP mode includes a level-sensitive mode and an edge-sensitive mode, either of which can be selected with the RELM (Bit6 in SYSCR1).

Note 1: During STOP period (from start of STOP mode to end of warm up), due to changes in the external interrupt pin signal, interrupt latches may be set to "1" and interrupts may be accepted immediately after STOP mode is released. Before starting STOP mode, therefore, disable interrupts. Also, before enabling interrupts after STOP mode is released, clear unnecessary interrupt latches.

(1) Level-sensitive release mode (RELM = "1")

In this mode, STOP mode is released by setting the \overline{STOP} pin high. This mode is used for capacitor backup when the main power supply is cut off and long term battery backup.

TENTATIVE

When the $\overline{\text{STOP}}$ pin input is high, executing an instruction which starts STOP mode will not place in STOP mode but instead will immediately start the release sequence (Warm up). Thus, to start STOP mode in the level-sensitive release mode, it is necessary for the program to first confirm that the $\overline{\text{STOP}}$ pin input is low. The following two methods can be used for confirmation.

1. Testing a port P20.
2. Using an external interrupt input $\overline{\text{INT5}}$ ($\overline{\text{INT5}}$ is a falling edge-sensitive input).

Example 1 :Starting STOP mode from NORMAL mode by testing a port P20.

```

LD      (SYSCR1), 01010000B    ; Sets up the level-sensitive release mode
SSTOPH: TEST   (P2PRD), 0      ; Wait until the  $\overline{\text{STOP}}$  pin input goes low level
        JRS    F, SSTOPH
        DI                    ; IMF ← 0
        SET   (SYSCR1), 7      ; Starts STOP mode
    
```

Example 2 :Starting STOP mode from NORMAL mode with an INT5 interrupt.

```

PINT5:  TEST   (P2PRD), 0      ; To reject noise, STOP mode does not start if
        JRS    F, SINT5        port P20 is at high
LD      (SYSCR1), 01010000B    ; Sets up the level-sensitive release mode.
        DI                    ; IMF ← 0
        SET   (SYSCR1), 7      ; Starts STOP mode
SINT5:  RETI
    
```

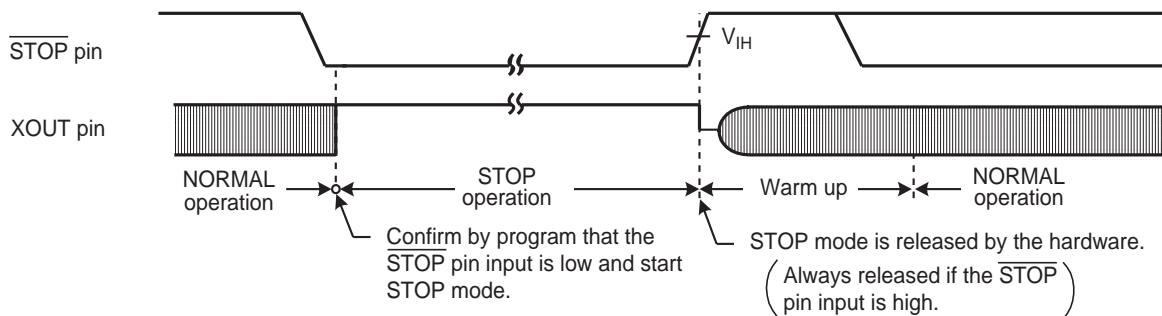

Figure 2-7 Level-sensitive Release Mode

Note 1: In this case of changing to the level-sensitive mode from the edge-sensitive mode, the release mode is not switched until a rising edge of the $\overline{\text{STOP}}$ pin input is detected.

(2) Edge-sensitive release mode (RELM = "0")

In this mode, STOP mode is released by a rising edge of the $\overline{\text{STOP}}$ pin input. This is used in applications where a relatively short program is executed repeatedly at periodic intervals. This periodic signal (for example, a clock from a low-power consumption oscillator) is input to the $\overline{\text{STOP}}$ pin. In the edge-sensitive release mode, STOP mode is started even when the $\overline{\text{STOP}}$ pin input is high level.

Example :Starting STOP mode from NORMAL mode

```

DI                    ; IMF ← 0
LD      (SYSCR1), 10010000B    ; Starts after specified to the edge-sensitive release mode
    
```

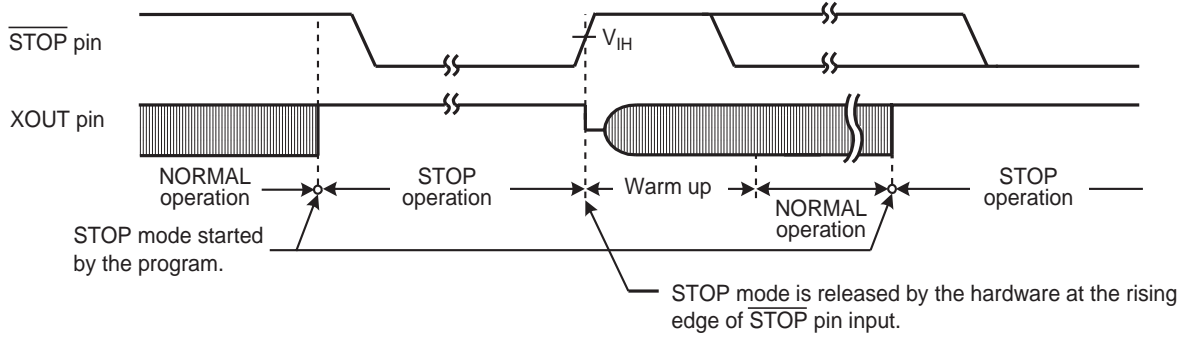

Figure 2-8 Edge-sensitive Release Mode

STOP mode is released by the following sequence.

1. In the dual-clock mode, when returning to NORMAL2, both the high-frequency and low-frequency clock oscillators are turned on; when returning to SLOW1 mode, only the low-frequency clock oscillator is turned on. In the single-clock mode, only the high-frequency clock oscillator is turned on.
2. A warm-up period is inserted to allow oscillation time to stabilize. During warm up, all internal operations remain halted. Four different warm-up times can be selected with the WUT (Bits 2 and 3 in SYSCR1) in accordance with the resonator characteristics.
3. When the warm-up time has elapsed, normal operation resumes with the instruction following the STOP mode start instruction. The start is made after the prescaler and the divider of the timing generator are cleared to "0".

Table 2-1 Warm-up Time Example (at $f_c = 16.0$ MHz, $f_s = 32.768$ kHz)

WUT	Warm-up Time [ms]	
	Return to NORMAL Mode	Return to SLOW Mode
00	12.288	750
01	4.096	250
10	3.072	5.85
11	1.024	1.95

Note: The warm-up time is obtained by dividing the basic clock by the divider. Therefore, the warm-up time may include a certain amount of error if there is any fluctuation of the oscillation frequency when STOP mode is released. Thus, the warm-up time must be considered as an approximate value.

STOP mode can also be released by inputting low level on the $\overline{\text{RESET}}$ pin, which immediately performs the normal reset operation.

Note: When STOP mode is released with a low hold voltage, the following cautions must be observed. The power supply voltage must be at the operating voltage level before releasing STOP mode. The $\overline{\text{RESET}}$ pin input must also be "H" level, rising together with the power supply voltage. In this case, if an external time constant circuit has been connected, the $\overline{\text{RESET}}$ pin input voltage will increase at a slower pace than the power supply voltage. At this time, there is a danger that a reset may occur if input voltage level of the $\overline{\text{RESET}}$ pin drops below the non-inverting high-level input voltage (Hysteresis input).

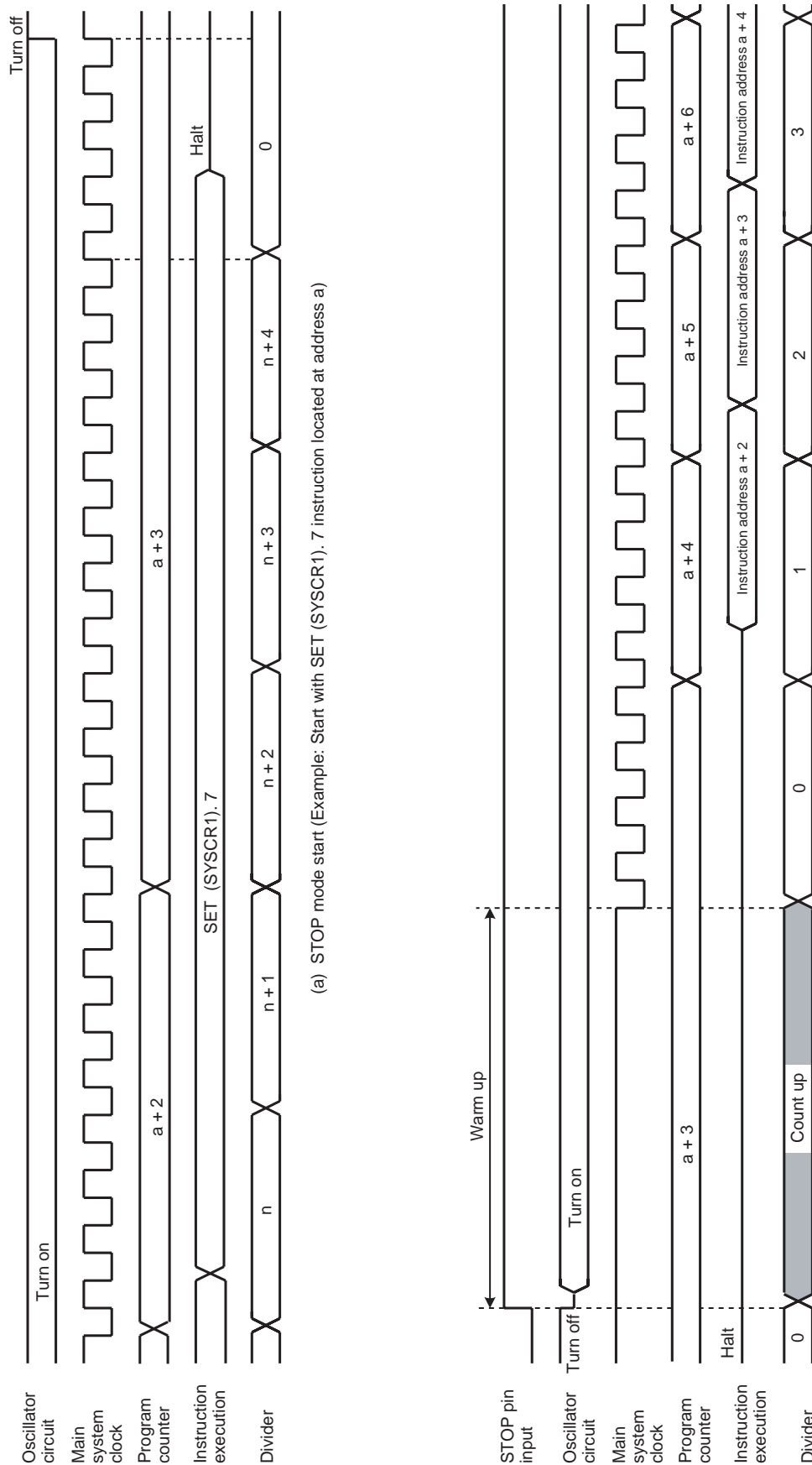

Figure 2-9 STOP Mode Start/Release

2.2.4.2 IDLE1/2 mode and SLEEP1/2 mode

IDLE1/2 and SLEEP1/2 modes are controlled by the system control register 2 (SYSCR2) and maskable interrupts. The following status is maintained during these modes.

1. Operation of the CPU and watchdog timer (WDT) is halted. On-chip peripherals continue to operate.
2. The data memory, CPU registers, program status word and port output latches are all held in the status in effect before these modes were entered.
3. The program counter holds the address 2 ahead of the instruction which starts these modes.

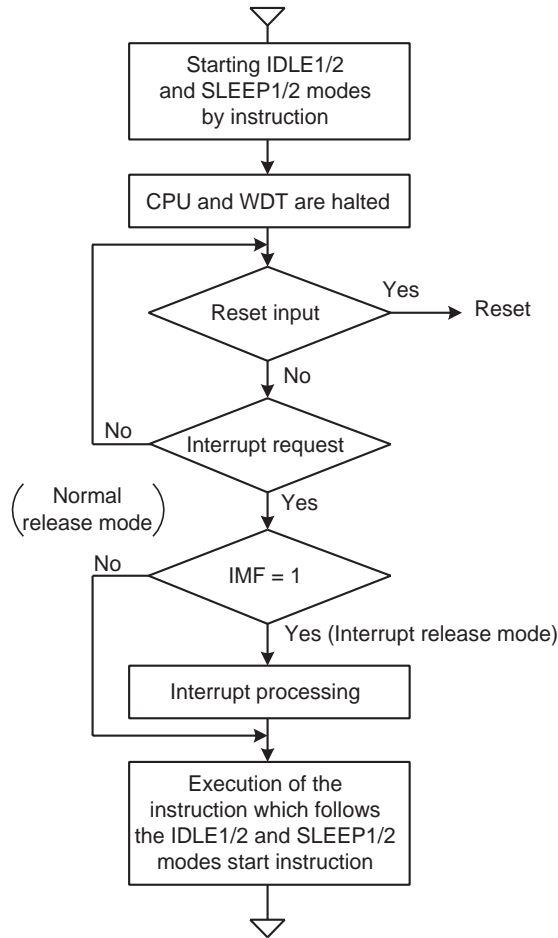

Figure 2-10 IDLE1/2 and SLEEP1/2 Modes

(1) Start the IDLE1/2 and SLEEP1/2 modes

When IDLE1/2 and SLEEP1/2 modes start, set SYSCR2<IDLE> to “1”. After IMF is set to “0”, set the individual interrupt enable flag (EF) which releases IDLE1/2 and SLEEP1/2.

(2) Release the IDLE1/2 and SLEEP1/2 modes

IDLE1/2 and SLEEP1/2 modes include a normal release mode and an interrupt release mode. These modes are selected by interrupt master enable flag (IMF). After releasing IDLE1/2 and SLEEP1/2 modes, the SYSCR2<IDLE> is automatically cleared to “0” and the operation mode is returned to the mode preceding IDLE1/2 and SLEEP1/2 modes.

IDLE1/2 and SLEEP1/2 modes can also be released by inputting low level on the RESET pin. After releasing reset, the operation mode is started from NORMAL1 mode.

(3) Normal release mode (IMF = "0")

IDLE1/2 and SLEEP1/2 modes are released by any interrupt source enabled by the individual interrupt enable flag (EF). After the interrupt is generated, the program operation is resumed from the instruction following the IDLE1/2 and SLEEP1/2 modes start instruction. Normally, the interrupt latches (IL) of the interrupt source used for releasing must be cleared to "0" by load instructions.

(4) Interrupt release mode (IMF = "1")

IDLE1/2 and SLEEP1/2 modes are released by any interrupt source enabled with the individual interrupt enable flag (EF) and the interrupt processing is started. After the interrupt is processed, the program operation is resumed from the instruction following the instruction, which starts IDLE1/2 and SLEEP1/2 modes.

Note: When a watchdog timer interrupts is generated immediately before IDLE1/2 and SLEEP1/2 mode are started, the watchdog timer interrupt will be processed but IDLE1/2 and SLEEP1/2 mode will not be started.

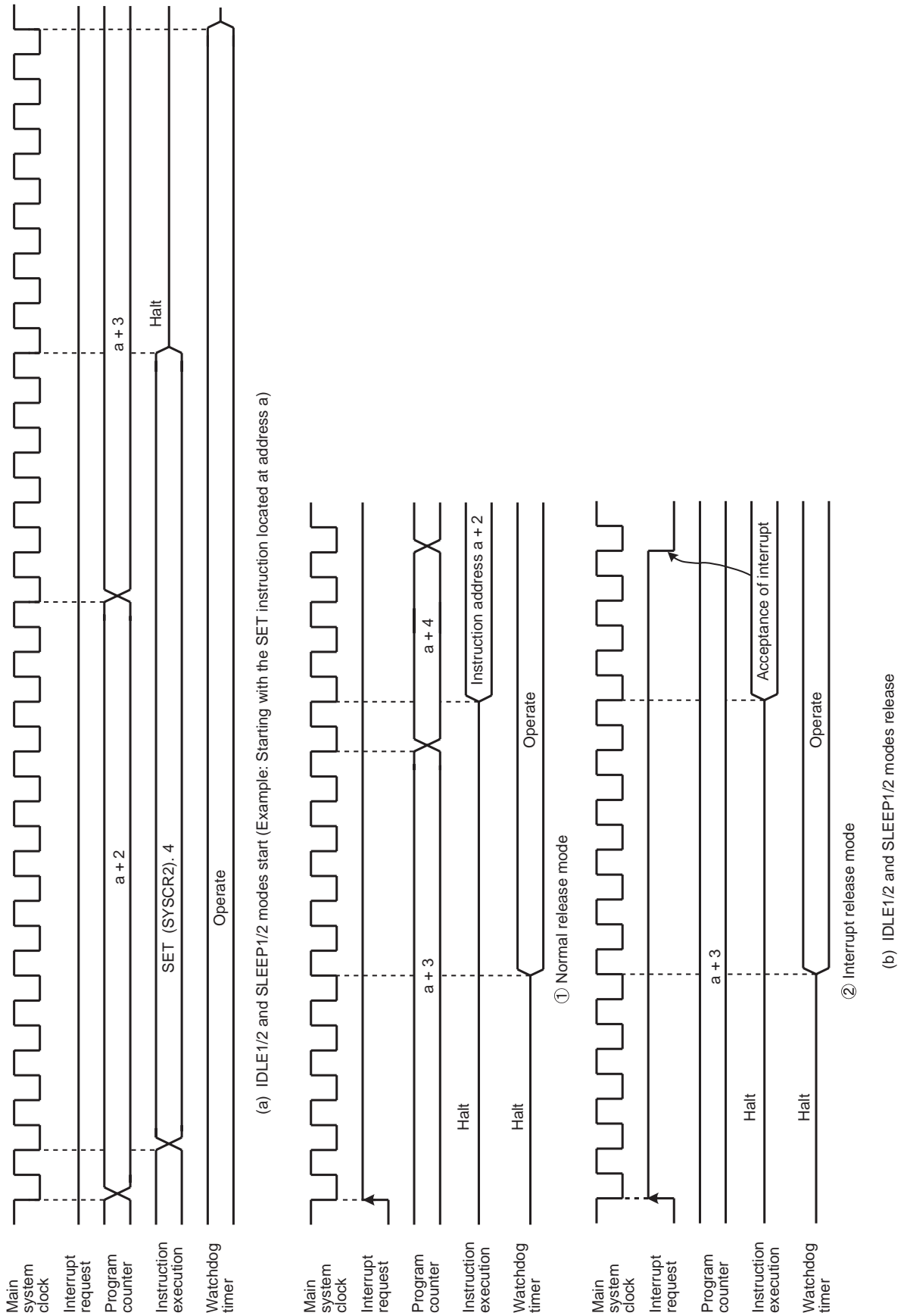

Figure 2-11 IDLE1/2 and SLEEP1/2 Modes Start/Release

TENTATIVE

2.2.4.3 IDLE0 and SLEEP0 modes (IDLE0, SLEEP0)

IDLE0 and SLEEP0 modes are controlled by the system control register 2 (SYSCR2) and the time base timer control register (TBTCCR). The following status is maintained during IDLE0 and SLEEP0 modes.

1. Timing generator stops feeding clock to peripherals except TBT.
2. The data memory, CPU registers, program status word and port output latches are all held in the status in effect before IDLE0 and SLEEP0 modes were entered.
3. The program counter holds the address 2 ahead of the instruction which starts IDLE0 and SLEEP0 modes.

Note: Before starting IDLE0 or SLEEP0 mode, be sure to stop (Disable) peripherals.

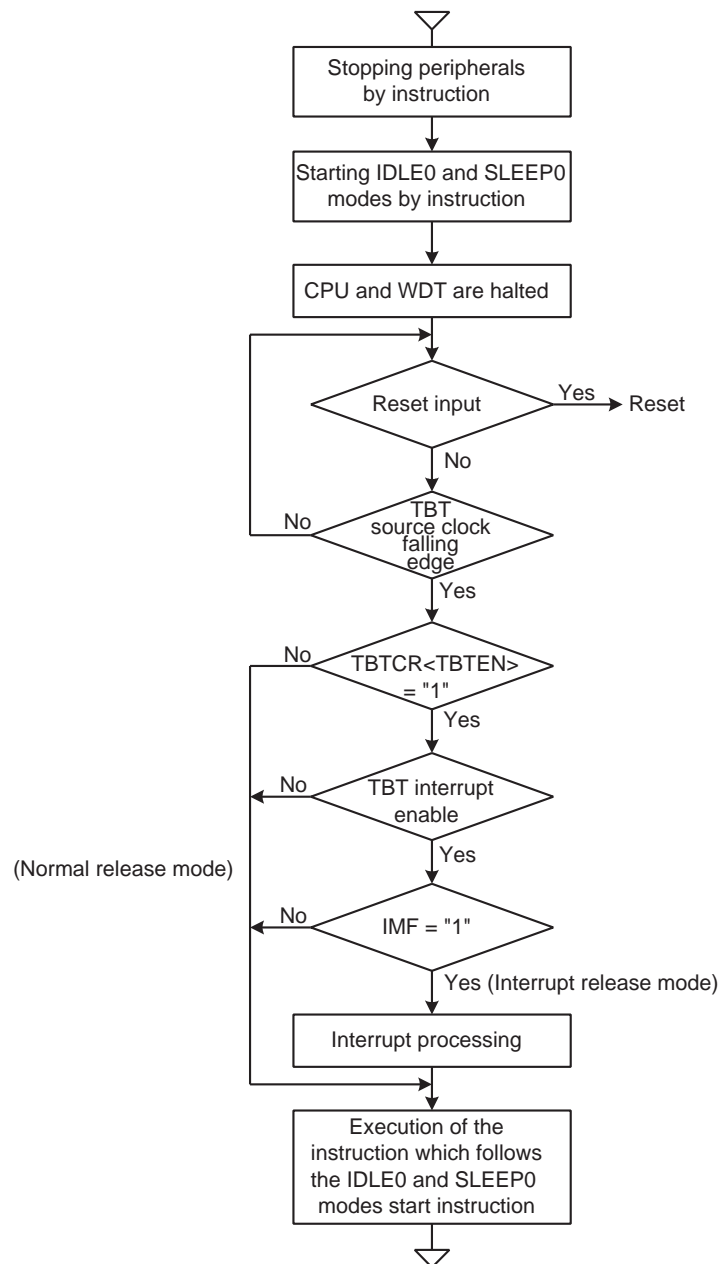

Figure 2-12 IDLE0 and SLEEP0 Modes

- (1) Start the IDLE0 and SLEEP0 modes

Stop (Disable) peripherals such as a timer counter.

When IDLE0 and SLEEP0 modes start, set SYSCR2<TGHALT> to “1”.

(2) Release the IDLE0 and SLEEP0 modes

IDLE0 and SLEEP0 modes include a normal release mode and an interrupt release mode.

These modes are selected by interrupt master flag (IMF), the individual interrupt enable flag of TBT and TBTCR<TBTEN>.

After releasing IDLE0 and SLEEP0 modes, the SYSCR2<TGHALT> is automatically cleared to “0” and the operation mode is returned to the mode preceding IDLE0 and SLEEP0 modes. Before starting the IDLE0 or SLEEP0 mode, when the TBTCR<TBTEN> is set to “1”, INTTBT interrupt latch is set to “1”.

IDLE0 and SLEEP0 modes can also be released by inputting low level on the $\overline{\text{RESET}}$ pin. After releasing reset, the operation mode is started from NORMAL1 mode.

Note: IDLE0 and SLEEP0 modes start/release without reference to TBTCR<TBTEN> setting.

(3) Normal release mode (IMF · EF7 · TBTCR<TBTEN> = “0”)

IDLE0 and SLEEP0 modes are released by the source clock falling edge, which is setting by the TBTCR<TBTCK> without reference to individual interrupt enable flag (EF). After the falling edge is detected, the program operation is resumed from the instruction following the IDLE0 and SLEEP0 modes start instruction.

(4) Interrupt release mode (IMF · EF7 · TBTCR<TBTEN> = “1”)

IDLE0 and SLEEP0 modes are released by the source clock falling edge, which is setting by the TBTCR<TBTCK> at INTTBT interrupt source enabled with the individual interrupt enable flag (EF) and INTTBT interrupt processing is started.

Note 1: Because returning from IDLE0, SLEEP0 to NORMAL1, SLOW1 is executed by the asynchronous internal clock, the period of IDLE0, SLEEP0 mode might be the shorter than the period setting by TBTCR<TBTCK>.

Note 2: When a watchdog timer interrupt is generated immediately before IDLE0/SLEEP0 mode is started, the watchdog timer interrupt will be processed but IDLE0/SLEEP0 mode will not be started.

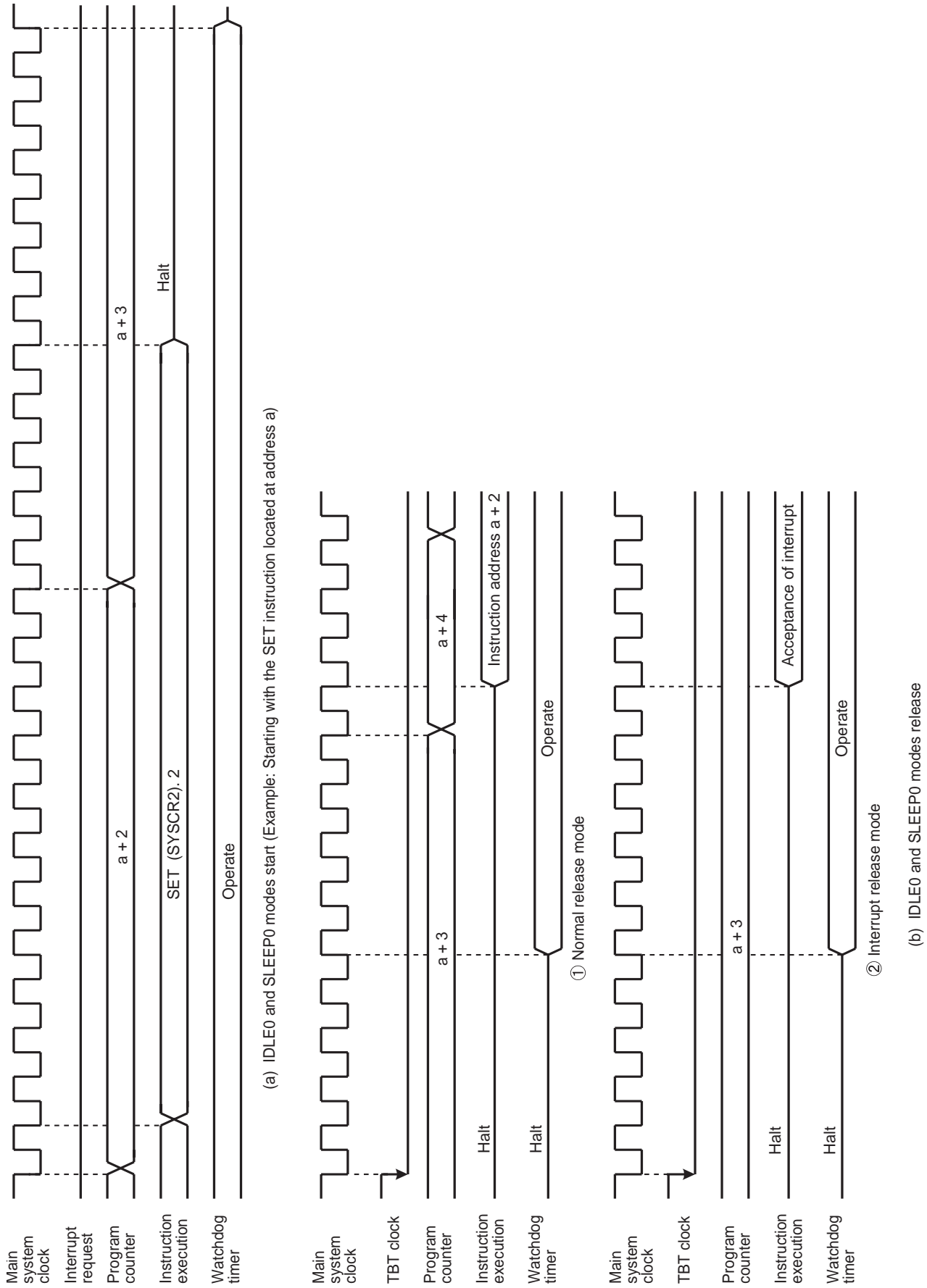

Figure 2-13 IDLE0 and SLEEP0 Modes Start/Release

2.2.4.4 SLOW mode

SLOW mode is controlled by the system control register 2 (SYSCR2).

The following is the methods to switch the mode with the warm-up counter (TC4, TC3).

(1) Switching from NORMAL2 mode to SLOW1 mode

First, set SYSCK (Bit5 in SYSCR2) to switch the main system clock to the low-frequency clock for SLOW2 mode.

Next, clear XEN (Bit7 in SYSCR2) to turn off high-frequency oscillation.

Note: The high-frequency clock can be continued oscillation in order to return to NORMAL2 mode from SLOW mode quickly. Always turn off oscillation of high-frequency clock when switching from SLOW mode to stop mode.

When the low-frequency clock oscillation is unstable, wait until oscillation stabilizes before performing the above operations. The timer/counter 6, 5, 4, 3 (TC6, TC5, TC4, TC3) can conveniently be used to confirm that low-frequency clock oscillation has stabilized.

Example 1 :Switching from NORMAL2 mode to SLOW1 mode.

```

SET      (SYSCR2). 5      ; SYSCR2<SYSCK> ← 1
                               (Switches the main system clock to the low-frequency
                               clock for SLOW2)
CLR      (SYSCR2). 7      ; SYSCR2<XEN> ← 0
                               (Turns off high-frequency oscillation)

```

Example 2 :Switching to the SLOW1 mode after low-frequency clock has stabilized.

```

SET      (SYSCR2). 6      ; SYSCR2<XTEN> ← 1
LD       (TC3CR), 43H     ; Sets mode for TC4, TC3 (16-bit TC, fs for source)
LD       (TC4CR), 05H
LDW     (TTREG3), 8000H   ; Sets warm-up time (Depend on oscillator accompanied)
DI                                             ; IMF ← 0
SET      (EIRH). 1       ; Enables INTTC4
EI                                             ; IMF ← 1
SET      (TC4CR). 3      ; Starts TC4, 3
:
PINTTC4: CLR      (TC4CR). 3      ; Stops TC4, 3
SET      (SYSCR2). 5      ; SYSCR2<SYSCK> ← 1
                               (Switches the main system clock to the low-frequency clock)
CLR      (SYSCR2). 7      ; SYSCR2<XEN> ← 0
                               (Turns off high-frequency oscillation)
RETI
:
VINTTC4: DW       PINTTC4      ; INTTC4 vector table

```

(2) Switching from SLOW1 mode to NORMAL2 mode

First, set XEN (Bit7 in SYSCR2) to turn on the high-frequency oscillation. When time for stabilization (Warm up) has been taken by the timer/counter 4, 3 (TC4, TC3), clear SYSCK (Bit5 in SYSCR2) to switch the main system clock to the high-frequency clock.

TENTATIVE

Note: After SYSCK is cleared to "0", executing the instructions is continued by the low-frequency clock for the period synchronized with low-frequency and high-frequency clocks.

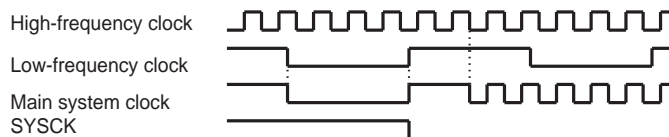

Note: SLOW mode can also be released by inputting low level on the RESET pin, which immediately performs the reset operation. After reset, TMP86FS49FG are placed in NORMAL1 mode.

Example :Switching from the SLOW1 mode to the NORMAL2 mode (fc = 16 MHz, warm-up time is 4.0 ms).

```

SET      (SYSCR2). 7      ; SYSCR2<XEN> ← 1 (Starts high-frequency oscillation)
LD       (TC3CR), 63H    ; Sets mode for TC4, TC3 (16-bit TC, fc for source)
LD       (TC4CR), 05H
LD       (TTREG4), 0F8H  ; Sets warm-up time
DI       ; IMF ← 0
SET      (EIRH). 1      ; Enables INTTC4
EI       ; IMF ← 1
SET      (TC4CR). 3      ; Starts TC4, 3
:
PINTTC4: CLR      (TC4CR). 3      ; Stops TC4, 3
CLR      (SYSCR2). 5      ; SYSCR2<SYSCK> ← 0
                                   ; (Switches the main system clock to the high-frequency clock)
RETI
:
VINTTC4: DW       PINTTC4      ; INTTC4 vector table

```

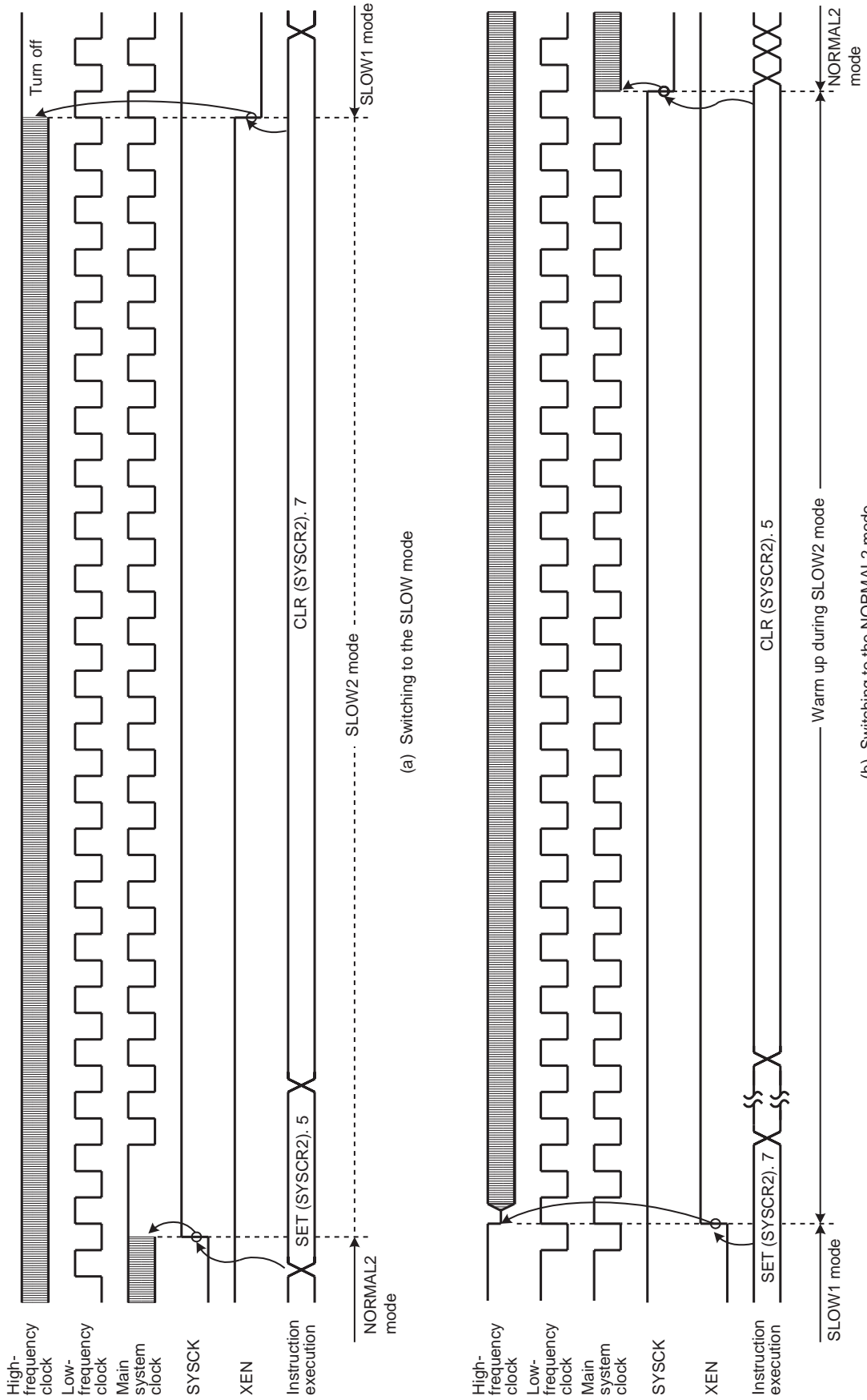

Figure 2-14 Switching between the NORMAL2 and SLOW Modes

2.3 Reset Circuit

The TMP86FS49FG have four types of reset generation procedures: An external reset input, an address trap reset, a watchdog timer reset and a system clock reset. Table 2-2 shows on-chip hardware initialization by reset action.

The malfunction reset circuit such as watchdog timer reset, address trap reset and system clock reset is not initialized when power is turned on. The $\overline{\text{RESET}}$ pin can reset state at the maximum $24/f_c$ [s] ($1.5 \mu\text{s}$ at 16.0 MHz) when power is turned on.

Table 2-2 Initializing Internal Status by Reset Action

On-chip Hardware	Initial Value	On-chip Hardware	Initial Value
Program counter (PC)	(FFFEH)	Prescaler and divider of timing generator	0
Stack pointer (SP)	Not initialized		
General-purpose registers (W, A, B, C, D, E, H, L, IX, IY)	Not initialized		
Jump status flag (JF)	Not initialized	Watchdog timer	Enable
Zero flag (ZF)	Not initialized	Output latches of I/O ports	Refer to I/O port circuitry
Carry flag (CF)	Not initialized		
Half carry flag (HF)	Not initialized		
Sign flag (SF)	Not initialized		
Overflow flag (VF)	Not initialized		
Interrupt master enable flag (IMF)	0		
Interrupt individual enable flags (EF)	0	Control registers	Refer to each of control register
Interrupt latches (IL)	0		
		RAM	Not initialized

2.3.1 External Reset Input

The $\overline{\text{RESET}}$ pin contains a Schmitt trigger (Hysteresis) with an internal pull-up resistor.

When the $\overline{\text{RESET}}$ pin is held at “L” level for at least 3 machine cycles ($12/f_c$ [s]) with the power supply voltage within the operating voltage range and oscillation stable, a reset is applied and the internal state is initialized.

When the $\overline{\text{RESET}}$ pin input goes high, the reset operation is released and the program execution starts at the vector address stored at addresses FFFEh to FFFFh.

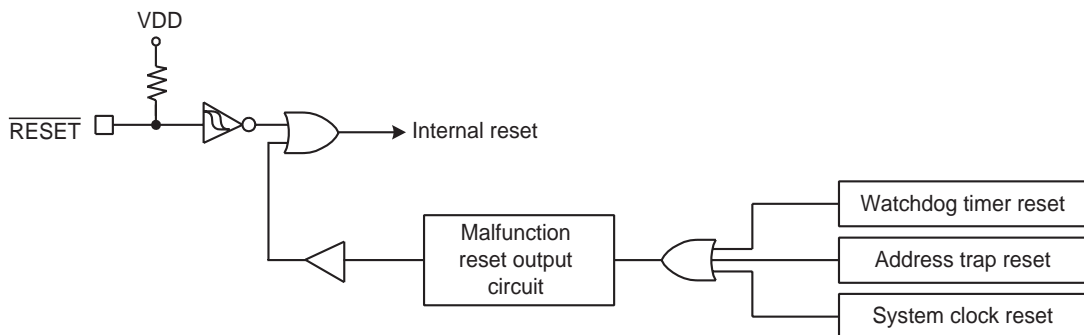
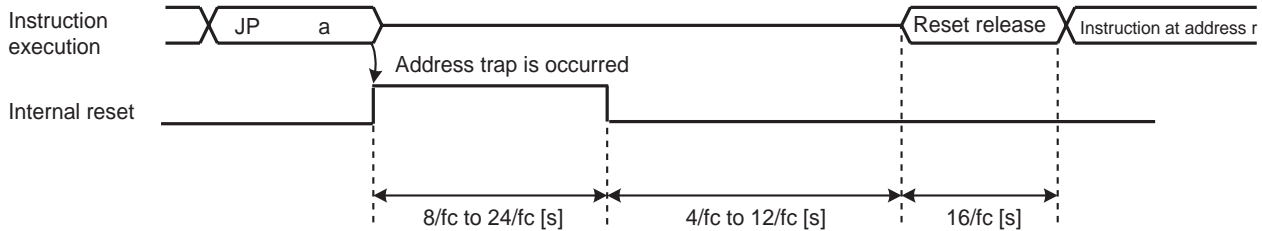

Figure 2-15 Reset Circuit

2.3.2 Address trap reset

If the CPU should start looping for some cause such as noise and an attempt be made to fetch an instruction from the on-chip RAM (when $WDTCR1<ATAS>$ is set to "1"), DBR or the SFR area, address trap reset will be generated. The reset time is about $8/f_c$ to $24/f_c$ [s] (0.5 to 1.5 μ s at 16.0 MHz).

Note: The operating mode under address trapped is alternative of reset or interrupt. The address trap area is alternative.



Note 1: Address "a" is in the SFR or on-chip RAM ($WDTCR1<ATAS> = "1"$) space.

Note 2: During reset release, reset vector "r" is read out, and an instruction at address "r" is fetched and decoded.

Figure 2-16 Address Trap Reset

2.3.3 Watchdog timer reset

Refer to 2.4 "Watchdog Timer".

2.3.4 System clock reset

Clearing both XEN and XTEN (Bits 7 and 6 in SYSCR2) to "0", clearing XEN to "0" when $SYSCK = "0"$, or clearing XTEN to "0" when $SYSCK = "1"$ stops system clock, and causes the microcomputer to deadlock. This can be prevented by automatically generating a reset signal whenever $XEN = XTEN = "0"$, $XEN = SYSCK = "0"$, or $XTEN = "0"/SYSCK = "1"$ is detected to continue the oscillation. The reset time is about $8/f_c$ to $24/f_c$ [s] (0.5 to 1.5 μ s at 16.0 MHz).

22. Electrical Characteristics

22.1 Absolute Maximum Ratings

The absolute maximum ratings are rated values which must not be exceeded during operation, even for an instant. Any one of the ratings must not be exceeded. If any absolute maximum rating is exceeded, a device may break down or its performance may be degraded, causing it to catch fire or explode resulting in injury to the user. Thus, when designing products which include this device, ensure that no absolute maximum rating value will ever be exceeded.

(VSS = 0 V)

Parameter	Symbol	Pins	Ratings	Unit
Supply voltage	V_{DD}		-0.3 to 6.5	V
Input voltage	V_{IN}		-0.3 to $V_{DD} + 0.3$	
Output voltage	V_{OUT1}		-0.3 to $V_{DD} + 0.3$	
Output current (Per 1 pin)	I_{OUT1}	P0, P1, P4, P6, P7 ports	-1.8	mA
	I_{OUT2}	P0, P1, P4, P6, P7 ports	3.2	
	I_{OUT3}	P3, P5 ports	30	
Output current (Total)	ΣI_{OUT1}	P0, P1, P4, P6, P7 ports	60	
	ΣI_{OUT2}	P3, P5 ports	80	
Power dissipation [Topr = 85 °C]	P_D		250	mW
Soldering temperature (time)	Tsld		260 (10 s)	°C
Storage temperature	Tstg		-55 to 125	
Operating temperature	Topr		-40 to 85	

22.2 Recommended Operating Conditions

The recommended operating conditions for a device are operating conditions under which it can be guaranteed that the device will operate as specified. If the device is used under operating conditions other than the recommended operating conditions (supply voltage, operating temperature range, specified AC/DC values etc.), malfunction may occur. Thus, when designing products which include this device, ensure that the recommended operating conditions for the device are always adhered to.

22.2.1 MCU mode (Flash Programming or erasing)

($V_{SS} = 0\text{ V}$, $T_{opr} = -10\text{ to }40^{\circ}\text{C}$)

Parameter	Symbol	Pins	Ratings	Min	Max	Unit
Supply voltage	V_{DD}		NORMAL1, 2 modes	4.5	5.5	V
Input high level	V_{IH1}	Except hysteresis input	$V_{DD} \geq 4.5\text{ V}$	$V_{DD} \times 0.70$	V_{DD}	
	V_{IH2}	Hysteresis input		$V_{DD} \times 0.75$		
Input low level	V_{IL1}	Except hysteresis input	$V_{DD} \geq 4.5\text{ V}$	0	$V_{DD} \times 0.30$	
	V_{IL2}	Except hysteresis input			$V_{DD} \times 0.25$	
Clock frequency	f_c	XIN, XOUT		1.0	16.0	

22.2.2 MCU mode (Except Flash Programming or erasing)

($V_{SS} = 0\text{ V}$, $T_{opr} = -40\text{ to }85^{\circ}\text{C}$)

Parameter	Symbol	Pins	Ratings	Min	Max	Unit
Supply voltage (Condition 1)	V_{DD}		$f_c = 16\text{ MHz}$	NORMAL1, 2 modes	4.5	5.5
			$f_s = 32.768\text{ KHz}$	IDLE0, 1, 2 modes		
			STOP mode			
Supply voltage (Condition 2)			$f_c = 8\text{ MHz}$	NORMAL1, 2 modes	3.0	3.6
			$f_s = 32.768\text{ KHz}$	IDLE0, 1, 2 modes		
			STOP mode			
Input high level	V_{IH1}	Except hysteresis input	$V_{DD} \geq 4.5\text{ V}$	$V_{DD} \times 0.70$	V_{DD}	
	V_{IH2}	Hysteresis input		$V_{DD} \times 0.75$		
	V_{IH3}			$V_{DD} < 4.5\text{ V}$		$V_{DD} \times 0.90$
Input low level	V_{IL1}	Except hysteresis input	$V_{DD} \geq 4.5\text{ V}$	0	$V_{DD} \times 0.30$	
	V_{IL2}	Hysteresis input			$V_{DD} \times 0.25$	
	V_{IL3}				$V_{DD} < 4.5\text{ V}$	$V_{DD} \times 0.10$
Clock frequency	f_c	XIN, XOUT	$V_{DD} = 3.0\text{ to }3.6\text{ V}, 4.5\text{ to }5.5\text{ V}$	1.0	8.0	MHz
	f_c	XIN, XOUT	$V_{DD} = 4.5\text{ to }5.5\text{ V}$	1.0	16.0	
	f_s	XTIN, XTOUT	$V_{DD} = 3.0\text{ to }3.6\text{ V}, 4.5\text{ to }5.5\text{ V}$	30.0	34.0	kHz

Note 1: The Supply voltage (V_{DD}) is divided into two different voltage areas. Do not change V_{DD} from Condition 1 to Condition 2 and vice versa while the MCU is operating. If you wish to use V_{DD} in a continuous range of 3.0V to 5.5V without stopping the MCU, please contact your local Toshiba office.

22.2.3 Serial PROM mode

(V_{SS} = 0 V, T_{opr} = -10 to 40 °C)

Parameter	Symbol	Pins	Condition	Min	Max	Unit
Supply voltage	V _{DD}		NORMAL 1, 2 modes	4.5	5.5	V
Input high voltage	V _{IH1}	Except hysteresis input	V _{DD} ≥ 4.5 V	V _{DD} × 0.70	V _{DD}	
	V _{IH2}	Hysteresis input		V _{DD} × 0.75		
Input low voltage	V _{IL1}	Except hysteresis input	V _{DD} ≥ 4.5 V	0	V _{DD} × 0.30	
	V _{IL2}	Hysteresis input			V _{DD} × 0.25	
Clock frequency	f _c	XIN, XOUT		2.0	16.0	MHz

22.3 DC Characteristics

(V_{SS} = 0 V, Topr = -40 to 85 °C)

Parameter	Symbol	Pins	Condition	Min	Typ.	Max	Unit				
Hysteresis voltage	V _{HS}	Hysteresis input		–	0.9	–	V				
Input current	I _{IN1}	TEST	V _{DD} = 5.5 V, V _{IN} = 5.5 V/0 V	–	–	±2	μA				
	I _{IN2}	Sink open drain, tri-state port									
	I _{IN3}	RESET, STOP									
Input resistance	R _{IN}	RESET pull-up		100	220	450	kΩ				
Output leakage current	I _{LO1}	Sink open drain port	V _{DD} = 5.5 V, V _{OUT} = 5.5 V	–	–	2	μA				
	I _{LO2}	Tri-state port	V _{DD} = 5.5 V, V _{OUT} = 5.5 V/0 V	–	–	±2					
Output high voltage	V _{OH}	Tri-state port	V _{DD} = 4.5 V, I _{OH} = -0.7 mA	4.1	–	–	V				
Output low voltage	V _{OL}	Except XOUT, P3, P5	V _{DD} = 4.5 V, I _{OL} = 1.6 mA	–	–	0.4					
Output low curren	I _{OL}	High current port (P3, P5 Port)	V _{DD} = 4.5 V, V _{OL} = 1.0 V	–	20	–	mA				
Supply current in NORMAL1, 2 modes	I _{DD}		V _{DD} = 5.5 V V _{IN} = 5.3 V/0.2 V fc = 16 MHz fs = 32.768 kHz	–	12.6	20		When a program operates on flash memory			
Supply current in IDLE0 mode									–	6.3	7.5
Supply current in IDLE 1, 2 modes									–	7.6	10
Supply current in SLOW1 mode			–	0.9	3	When a program operates on RAM					
Supply current in SLEEP1 mode			V _{DD} = 3.0 V V _{IN} = 2.8 V/0.2 V fs = 32.768 kHz	–	10			21			
Supply current in SLEEP0 mode				–	4.5			16			
Supply current in STOP mode				–	3.5		12				
Supply current in STOP mode	V _{DD} = 5.5 V V _{IN} = 5.3 V/0.2 V	–		0.5	10						

Note 1: Typical values show those at Topr = 25°C and V_{DD} = 5 V.

Note 2: Input current (I_{IN1}, I_{IN3}): The current through pull-up or pull-down resistor is not included.

Note 3: I_{DD} does not include I_{REF}.

Note 4: The supply currents of SLOW2 and SLEEP2 modes are equivalent to those of IDLE1 and IDLE2 modes.

22.4 AD Characteristics

(V_{SS} = 0.0 V, 4.5 V ≤ V_{DD} ≤ 5.5 V, Topr = -40 to 85 °C)

Parameter	Symbol	Condition	Min	Typ.	Max	Unit
Analog reference voltage	V _{AREF}		A _{VDD} - 1.0	–	A _{VDD}	V
Power supply voltage of analog control circuit	A _{VDD}		V _{DD}			
Analog reference voltage range (Note 4)	Δ V _{AREF}		3.5	–	–	
Analog input voltage	V _{AIN}		V _{SS}	–	V _{AREF}	
Power supply current of analog reference voltage	I _{REF}	V _{DD} = A _{VDD} = V _{AREF} = 5.5 V V _{SS} = A _{VSS} = 0.0 V	–	0.6	1.0	mA
Non linearity error		V _{DD} = A _{VDD} = 5.0 V, V _{SS} = A _{VSS} = 0.0 V V _{AREF} = 5.0 V	–	–	±2	LSB
Zero point error			–	–	±2	
Full scale error			–	–	±2	
Total error			–	–	±2	

(V_{SS} = 0 V, 3.0 V ≤ V_{DD} ≤ 3.6 V, Topr = -40 to 85 °C)

Parameter	Symbol	Condition	Min	Typ.	Max	Unit
Analog reference voltage	V _{AREF}		A _{VDD} - 1.0	–	A _{VDD}	V
Power supply voltage of analog control circuit	A _{VDD}		V _{DD}			
Analog reference voltage range (Note 4)	Δ V _{AREF}		2.5	–	–	
Analog input voltage	V _{AIN}		V _{SS}	–	V _{AREF}	
Power supply current of analog reference voltage	I _{REF}	V _{DD} = A _{VDD} = V _{AREF} = 3.6 V V _{SS} = A _{VSS} = 0.0 V	–	0.5	0.8	mA
Non linearity error		V _{DD} = A _{VDD} = 3.0 V, V _{SS} = A _{VSS} = 0.0 V V _{AREF} = 3.0 V	–	–	±2	LSB
Zero point error			–	–	±2	
Full scale error			–	–	±2	
Total error			–	–	±2	

Note 1: The total error includes all errors except a quantization error, and is defined as a maximum deviation from the ideal conversion line.

Note 2: Conversion time is different in recommended value by power supply voltage.

Note 3: The voltage to be input on the AIN input pin must not exceed the range between V_{AREF} and V_{SS}. If a voltage outside this range is input, conversion values will become unstable and conversion values of other channels will also be affected.

Note 4: Analog reference voltage range: ΔV_{AREF} = V_{AREF} - V_{SS}

Note 5: When AD converter is not used, fix the AVDD and VAREF pin on the V_{DD} level.

22.5 AC Characteristics

($V_{SS} = 0\text{ V}$, $V_{DD} = 4.5\text{ V to }5.5\text{ V}$, $T_{opr} = -40\text{ to }85^{\circ}\text{C}$)

Parameter	Symbol	Condition	Min	Typ.	Max	Unit
Machine cycle time	t_{cy}	NORMAL1, 2 modes	0.25	-	4	μs
		IDLE0, 1, 2 modes				
		SLOW1, 2 modes	117.6	-	133.3	
		SLEEP0, 1, 2 modes				
High-level clock pulse width	t_{WCH}	For external clock operation (XIN input) $f_c = 16\text{ MHz}$	-	31.25	-	ns
Low-level clock pulse width	t_{WCL}					
High-level clock pulse width	t_{WSH}	For external clock operation (XTIN input) $f_s = 32.768\text{ kHz}$	-	15.26	-	μs
Low-level clock pulse width	t_{WSL}					

($V_{SS} = 0\text{ V}$, $V_{DD} = 3.0\text{ V to }3.6\text{ V}$, $T_{opr} = -40\text{ to }85^{\circ}\text{C}$)

Parameter	Symbol	Condition	Min	Typ.	Max	Unit
Machine cycle time	t_{cy}	NORMAL1, 2 modes	0.5	-	4	μs
		IDLE0, 1, 2 modes				
		SLOW1, 2 modes	117.6	-	133.3	
		SLEEP0, 1, 2 modes				
High-level clock pulse width	t_{WCH}	For external clock operation (XIN input) $f_c = 8\text{ MHz}$	-	62.5	-	ns
Low-level clock pulse width	t_{WCL}					
High-level clock pulse width	t_{WSH}	For external clock operation (XTIN input) $f_s = 32.768\text{ kHz}$	-	15.26	-	μs
Low-level clock pulse width	t_{WSL}					

22.6 Flash Characteristics

22.6.1 Write/Retention Characteristics

($V_{SS} = 0\text{ V}$)

Parameter	Condition	Min	Typ.	Max.	Unit
Number of guaranteed writes to flash memory	$V_{SS} = 0\text{ V}$, $T_{opr} = -10\text{ to }40^{\circ}\text{C}$	-	-	100	Times

22.7 Recommended Oscillating Conditions

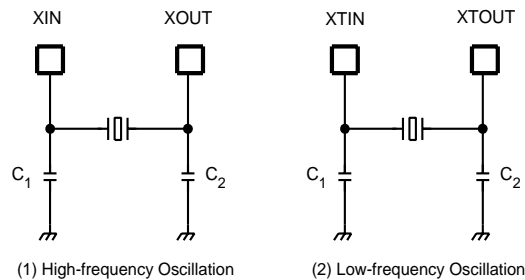

Note 1: To ensure stable oscillation, the resonator position, load capacitance, etc. must be appropriate. Because these factors are greatly affected by board patterns, please be sure to evaluate operation on the board on which the device will actually be mounted.

Note 2: The product numbers and specifications of the resonators by Murata Manufacturing Co., Ltd. are subject to change. For up-to-date information, please refer to the following URL:
<http://www.murata.co.jp/search/index.html>

22.8 Handling Precaution

- The solderability test conditions for lead-free products (indicated by the suffix G in product name) are shown below.

1. When using the Sn-63Pb solder bath
 - Solder bath temperature = 230 °C
 - Dipping time = 5 seconds
 - Number of times = once
 - R-type flux used
2. When using the Sn-3.0Ag-0.5Cu solder bath
 - Solder bath temperature = 245 °C
 - Dipping time = 5 seconds
 - Number of times = once
 - R-type flux used

Note: The pass criterion of the above test is as follows:

Solderability rate until forming ≥ 95 %

- When using the device (oscillator) in places exposed to high electric fields such as cathode-ray tubes, we recommend electrically shielding the package in order to maintain normal operating condition.

